



**net**  
North East  
Telecommunications Ltd

## PRODUCT DATASHEET



## Dual-band ATEX / Ex Crane Radio System

A fully certified digital two-way marine radio system covering VHF and UHF bands for installation in hazardous areas where Safety is a priority and space is at a premium.

# ATEX / Ex Dual-band Crane Radio System

For over 20 years NET are experts in manufacturing Ex Dual-band Crane Radio Systems, providing best in class reliability and safety to support offshore operations.

This latest generation is a fully certified radio solution from an ISO9001 accredited supplier offering unrivalled support and service throughout the product life-cycle. Designed specifically for offshore cranes located in hazardous areas up to Zone 1 to provide crystal clear communications, ATEX safety compliance, ergonomics and ease of use.

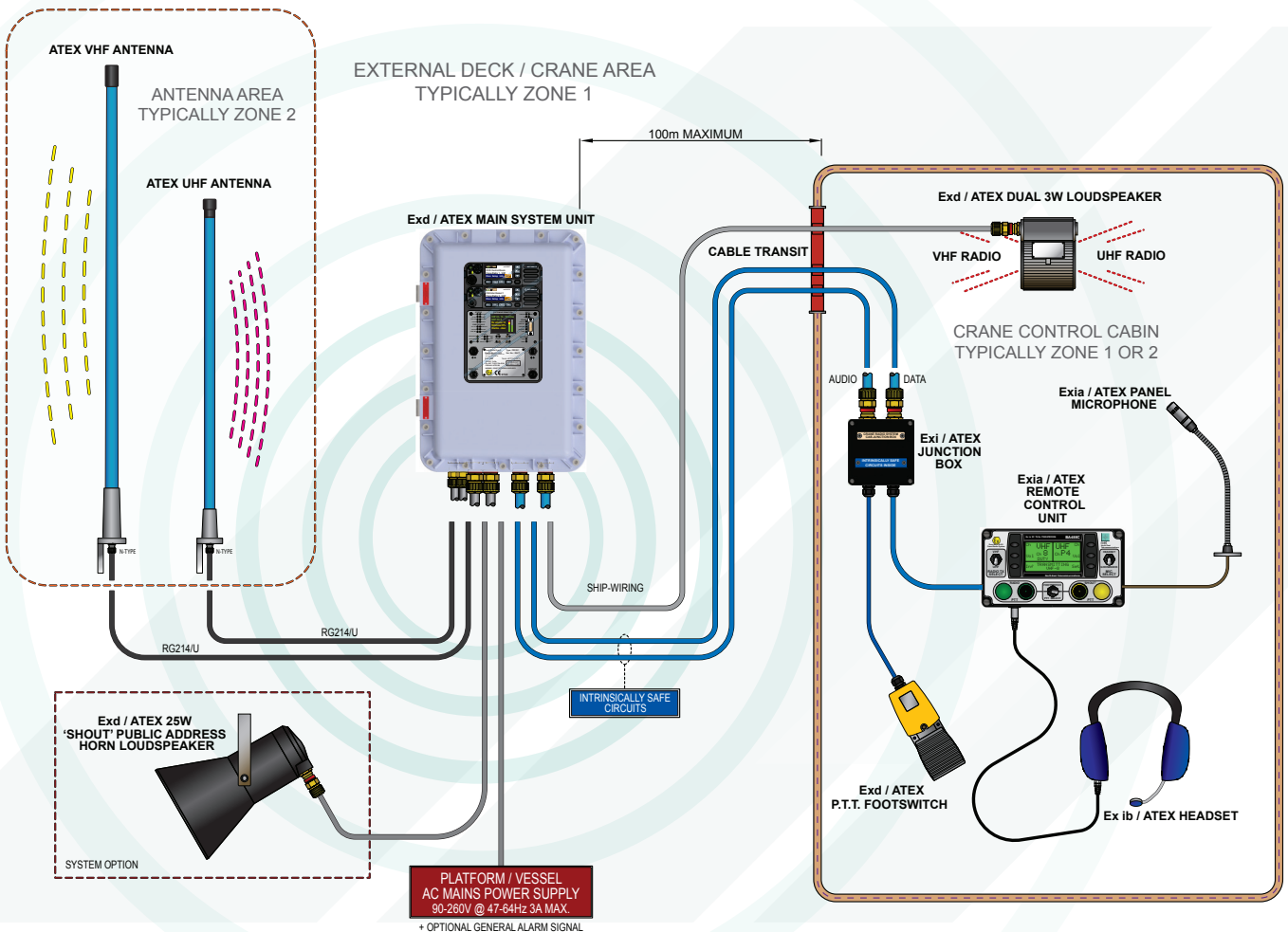

Compact cab Remote Control Unit



Integrated hands-free 25W 'Shout' PA system



Certified turnkey system with installation specific documentation



VHF + UHF radios, system controller and antennas can be outside the cab



Latest Motorola radios and enhanced audio processing for user comfort



Designed for ease of installation. Supported 24/7/365 by the manufacturer



**net**  
North East  
Telecommunications Ltd

## Contact

133 & 133A Victoria Street, Dyce, Aberdeen, AB21 7BJ  
T : 01224 775717 (24 hours) E : info@netltd.co.uk

[netltd.co.uk](http://netltd.co.uk)

## Trusted Partner

North East Telecommunications has been supplying marine two-way radio systems to the offshore industry for over 25 years with thousands of radio systems in constant operation worldwide in a variety of safe and hazardous area applications.

As a Motorola Platinum Partner and the second largest reseller of ATEX Motorola radio equipment in the UK, NET has access to the latest technologies and support networks from Motorola and can supply, install and maintain systems from individual radios to the latest complex turnkey digital infrastructures.

NET have been manufacturing and supplying similar ATEX / Ex crane radio systems for over 20 years, with this latest product building on a proven pedigree and experience to offer Customers the latest digital technologies to enhance operations and safety.

EXD MAIN SYSTEM UNIT –  
ALL CONNECTIONS ON THE BASE



## Benefits



### TO THE OWNER:

- Integrates with latest digital radio systems being deployed offshore with the latest safety features.
- Assured and trusted supply partner with unrivalled support and service pedigree.
- Providing best in class reliability and safety to support critical offshore lifting operations.
- Knowledge that operators are provided with best ergonomics and comfort.
- Online user competency training and familiarisation provided – with accessible user training record / certificate.
- Comprehensive Extended Warranty included.
- 24/7/365 onshore support available.
- Simple on-line video-based user training provided.

### TO THE USER:

- Easy to use.
- Reduces stress through low-noise clear audio performance.
- Full adjustability of listening volumes from all sources.
- Adjustable 'ambient' sound included in headset audio for local awareness / monitoring.
- Toggle selection of which radio has transmit 'duty' (VHF / UHF).
- Toggle selection of configurable 'Home' and Emergency channels for simplified use.
- Footswitch for hands-free radio / P.A. control during critical operations.
- Levels 'Profile' can be saved and recalled for each operator for convenience at the beginning of shift.

### TO THE TECHNICAL TEAM:

- Ease of installation and integration within new or existing infrastructure.
- Pre-installation survey available with approved survey and installation procedures.
- Documentation package with Customer specific installation drawings, procedures and information.
- Latest digital technology with full diagnostics and monitoring.
- Wireless access to configuration, status, event history and diagnostics without the need to open Main System Unit Exd enclosure.
- Comprehensive diagnostic software running on ATEX tablet.
- System Controller to tablet diagnostic cable with mode select switches and technician headset socket.



net

North East  
Telecommunications Ltd

## Contact

133 & 133A Victoria Street, Dyce, Aberdeen, AB21 7BJ  
T : 01224 775717 (24 hours) E : info@netltd.co.uk

netltd.co.uk

## System Description

A certified digital two-way marine radio system covering VHF and UHF bands for installation on cranes located in hazardous areas and where space in the control cab is at a premium.

The latest technology is used in the optimised design for critical communications between crane operators and deck personnel or vessel crew attending the installation. The system provides a fully certified ATEX / IECEx solution allowing use with cranes located in hazardous areas up to Zone 1 gas group IIB + H2 (Optional IIC).

The crane operator has a compact Zone 1 rated Remote Control Unit (RCU) within easy reach and view to make system adjustments such as selecting between VHF or UHF radio for transmit, adjusting radio channels and setting speaker or headset volume. Several different mounting bracket types are available to ensure optimal placement of this unit.

Cab loudspeakers and a gooseneck panel microphone can be used instead of the ATEX headset, depending on operator preference.

The system includes a 25W 'Shout' public address system allowing the crane operator to make announcements immediately to deck personnel – particularly important during critical lifting operations where the operator may have a better view of the deck area and can warn others at risk.

Hands-free operation of the transmit function is provided by a footswitch and/or connection to an existing crane control joystick button.

Up to 15 dedicated channels can be programmed into each radio, selectable by the crane operator with quick access to a 'home' or 'calling' channel. Radio channels can be either analogue or digital to integrate with any infrastructure and provide the facility for both analogue and digital private line calling schemes (TPL or DPL).

The system can integrate with a General Alarm or Shutdown Alarm to either limit transmit power or prevent all radio transmissions in the event of a critical situation. This safety feature can allow higher transmit power use in normal conditions.

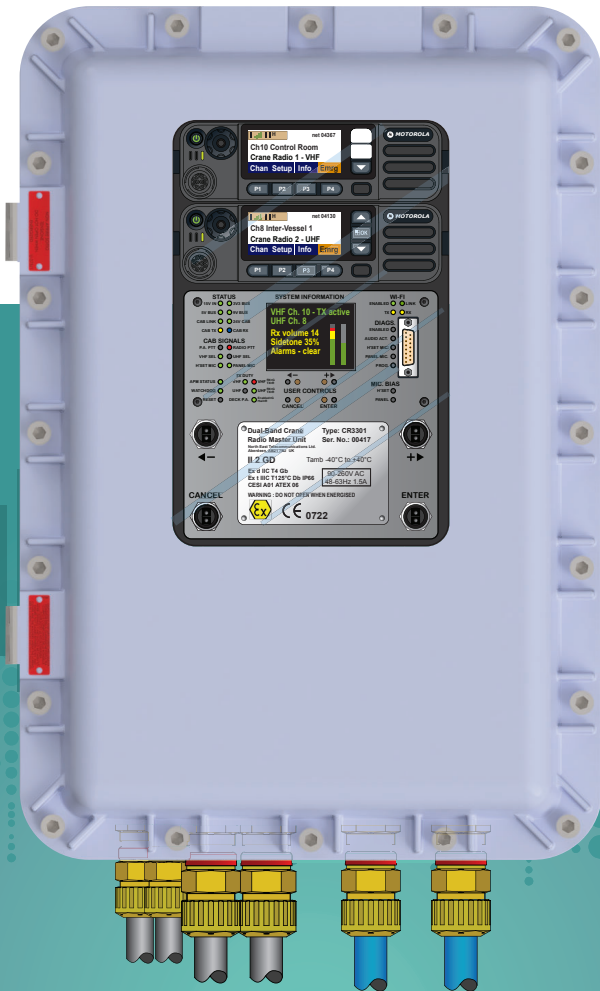

## Applications

- Offshore cranes located in hazardous areas.
- Space constrained crane control cabs.
- Upgrade of existing systems to higher performance, safer equipment.
- Digitalisation of legacy analogue installations.
- Offshore production platforms, drilling rigs, FPSOs & Well Intervention vessels.



**net**  
North East  
Telecommunications Ltd

## Contact

133 & 133A Victoria Street, Dyce, Aberdeen, AB21 7BJ  
T : 01224 775717 (24 hours) E : [info@netltd.co.uk](mailto:info@netltd.co.uk)

[netltd.co.uk](http://netltd.co.uk)

# System Description cont.

An important safety feature incorporated into the system is continuous monitoring of radio transmit power. ATEX regulations specify the maximum radiated power allowed for different gas groups, but this is normally never checked or monitored meaning that a system fault could cause dangerous transmit power levels presenting a serious risk to safety. The NET system has an independent 'safety processor' that monitors transmit power levels continuously and ensures safe operations.

The Main System Unit (MSU) is based on an Exd ATEX enclosure which may be located outside the crane cab in a suitable position. This unit houses the two radio transceivers which are the latest generation of Motorola DM4601e transceivers, programmable for analogue or digital operation and with output power levels from 1W to 25W. Other transceiver models are optional.

The MSU enclosure also houses the System Controller which manages the radios and the crane cab Remote Control Unit. This is a state of the art design using advanced digital signal processing techniques to provide highest quality audio signals that ensure crystal clear communications. The audio levels are dynamically adjusted and controlled with dedicated settings configurable for up to 6 different users. This allows each crane operator to set and save their own preferences for recall at the start of their shift.

A window in the MSU front cover allows technicians to monitor the system status and make configuration changes without disturbing crane operations. A Wi-Fi link also allows the technician to perform full configuration and diagnostics using a suitably certified ATEX tablet without the need to open the Exd enclosure.

Two separate ATEX certified antennas are used, each with its own lightning surge arrestor inside the MSU. Antennas are mounted in a suitable position on the crane to give optimised coverage of the deck areas and approaching vessels.

A single AC mains power supply is required and this can be connected from the crane power distribution panel or other suitable source.

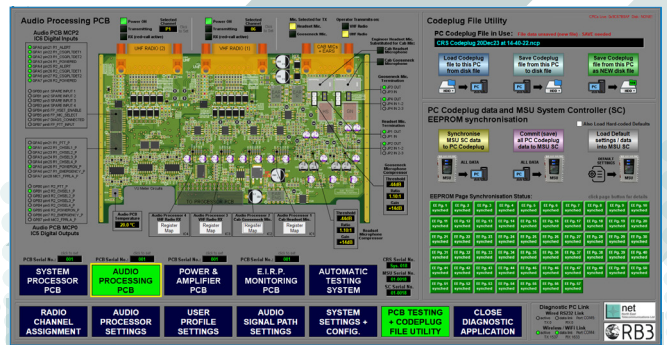
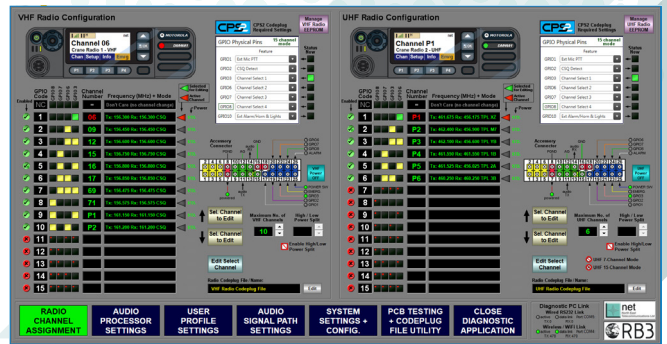
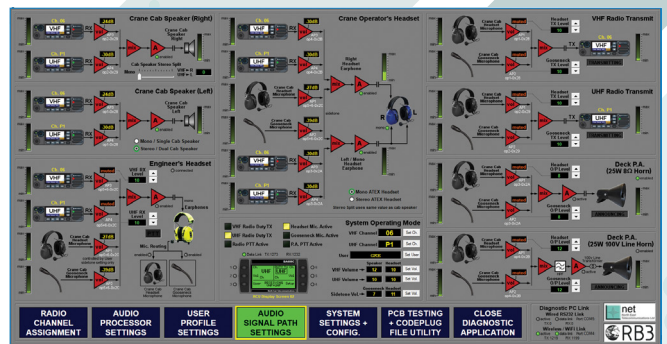
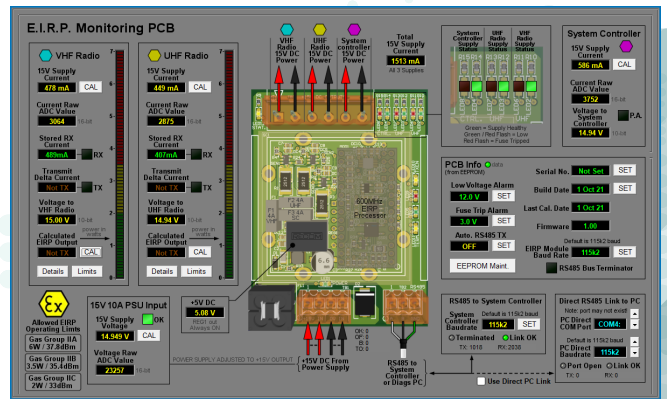

**net**  
North East  
Telecommunications Ltd

## Contact

133 & 133A Victoria Street, Dyce, Aberdeen, AB21 7BJ  
T : 01224 775717 (24 hours) E : info@netltd.co.uk

netltd.co.uk

# Specifications (Specifications subject to change without notification)

## Hazardous Area Certification (complete system):

ATEX / IECEx Zone:	Zone 1, Equipment Category 2
Gas Group:	IIB + H2 (optional IIC)
Temperature Class:	T4 (-20°C < Ta < +55°C)

## Power Requirements:

Power supply input:	Single-phase AC 90-260V @ 47-63Hz 100W max.
Supply Current:	Typical 0.5A, 1.1A @ 90V max. Inrush 4A max.

## Radio Transceivers:

VHF Operating Frequency Range:	136-174 MHz
UHF Operating Frequency Range:	403-470 MHz
Programmable Channels per band:	15
Power level groups per band:	2
Transmit power adjustment range:	1W to 25W in 0.1W increments
Channel Spacing:	12.5kHz / 25kHz
CTCSS Signalling:	Analogue TPL, 50 standard EIA/TIA tones Digital DPL, 83 standard TIA codes

## Audio Systems:

Operator Selected Mic. Inputs:	ATEX Headset boom microphone or ATEX dynamic gooseneck microphone
Cab Loudspeaker:	2-channel 3W each, configurable VHF/UHF
Audio Processing:	4-channel, 3-band EQ, microphone compressor Dynamic level controls & mixing, settings saved
Headphones:	Mono or Stereo channels

## 'Shout' Public Address (PA) System:

Rated power output:	2 x 25W channels, adjustable level
Operating Mode / Voltage:	Channel 1 - 70/100V line, Channel 2 - 8 ohm

## Weights & Dimensions:

Main system Unit (MSU):	H 567mm, W 388mm, D 298mm (excluding glands) Installed weight 45kg (Alu IIB + H2 Option)
Remote Control Unit (RCU):	H 120mm, W 220mm, D 110mm (excluding bracket) Installed weight 2kg
Crane Cab Junction Box:	H 160mm, W 160mm, D 90mm Installed weight 2kg

## Environmental Specification:

Main system Unit (MSU):	IP66 protection ambient temperature -20°C to +55°C
Remote Control Unit (RCU):	IP66 (headset connected) ambient temperature -20°C to +60°C

## CORE ATEX SYSTEM DELIVERABLES:

- Dual-band CRS Main System Unit (MSU)
- Crane Cab Remote Control Unit (RCU) & mounting bracket
- Crane Cab Junction Box
- VHF Marine Antenna & mounting bracket
- UHF Marine Antenna & mounting bracket
- Wired headset with boom microphone
- Gooseneck microphone & mounting bracket
- Press to Talk Footswitch
- Dual-channel 3W Loudspeaker
- Documentation Package

## OPTIONAL / CONFIGURED SYSTEM COMPONENTS:

- 'Shout' Public Address horn loudspeaker (70/100V line or 8-ohm)
- General Alarm signal interface module
- RCU mounting brackets / system options
- GRP weather protection enclosure for MSU
- ATEX certified diagnostic tablet PC

## INSTALLATION MATERIALS:

- Shipwiring fixed installation cables
- ATEX Barrier cable glands for MSU entries
- Cable supports, transits & identification labels
- Installation specific equipment mounting brackets / fixtures



## Contact

133 & 133A Victoria Street, Dyce, Aberdeen, AB21 7BJ  
T : 01224 775717 (24 hours) E : info@netltd.co.uk

netltd.co.uk